

# ZERO WASTE

UNBREAKABLE FOUNDATIONS 

*"A resilience-based approach to infrastructure is vital so we can better adapt to change and reduce our exposure to risk.*

*Decisions made today, particularly those related to the redesign and retrofitting of infrastructure, will affect how well our network is able to adapt to change into the future."*

Main Roads WA

**INNOVATOR OF THE YEAR  
WORKSAFE AWARD DOH&S  
APPROVED NATIONALLY**

unlike anything you've seen before,  
this is truly a game changer

**For the first time in history, we have the  
technology to put an end to damage and  
repeated replacements**

For the first time in history instead of repeatedly replacing traffic islands and footpaths, disposing of valuable concrete, we can ensure they remain in good working condition for decades to come

**With no ongoing repair cost for the next  
100 years the savings are substantial**

This overcomes many of the biggest problems facing our industry today from increasing workloads, to increasing costs; workplace safety; carbon waste and the ongoing consumption of carbon resources

Awarded Innovator of the Year by Dept of Commerce and Worksafe Award by Dept of Occupational Health & Safety this technology is the only device that meets national standards for safety and reliability and consequently has been approved for use in all states.



# 05

Providing a simple solution to five of the biggest problems facing our industry today

## 1. Carbon waste

Current methods are consuming vast quantities of carbon intensive concrete. We are already borrowing resources from future generations and with rapid urbanisation the damage, carbon waste and consumption of finite resources is growing – providing no future benefit.



## 2. Growing disturbance

The disturbance to traffic flow and pedestrians has become a major problem in our cities resulting in a growing number of roadworks, increasing costs and disturbance to public and with rapid urbanisation the disturbance is set to increase dramatically



## 3. Growing difficulty

Building and maintaining roads is hard work, dealing with traffic, angry drivers and a growing number of dangerous and poorly mapped underground services, our road workers are risking their lives on daily basis. and with fast growing urbanization this job is becoming increasingly dangerous.



## 4. Growing Costs

Repeatedly replacing valuable concrete footings provides no future benefit so every year the costs continue to grow. With ever increasing safety and environmental pressures, global unrest and depleting resources, the cost of materials is rapidly increasing as the gap between the growing demand and the finite budgets continues to grow



## 5. Risk of cost overruns

It's hard enough to budget with the rapidly increasing cost of carbon intensive supplies, but it's the unknown variables, such as delays caused by heavy traffic or rain; injury caused by working in traffic; back injuries from digging and heavy labour; or costly damage to the growing number of (often poorly mapped) underground services, that cause havoc with budgets and the risk of cost overruns is growing.



The worst part is that all this hard work provides no future benefit so every year the costs and risks continue to grow.

**We decided it was time to put an end to this madness!**



## You told us your problems, and we listened

Until now all we had were metal devices (and units made from traditional plastics such as PVC) which provide a short-term benefit, although create a major long-term problem as they will not last 100 years. You told us the problems you had with existing devices, and we have overcome every one of them.

### 1. Metal prone to rust

Metal is prone to rust and corrosion and the concrete creates a corrosive force on metal creating dangerous litigation risks and reducing the lifespan of the item

**SOLUTION:** Instead of using metal we utilised a self-healing plastic to create a protective shield between the item and the concrete protecting the item from rust and making the item recyclable

### 2. Not Impact resistant

Metal is not malleable so when impacted the impact force can distort the metal, damaging the device and the surrounding foundations

**SOLUTION:** Instead of using metal we utilised a shock absorbing advanced linear hydrocarbon polymer to create a protective shield between the item and the foundations. This advanced polymer is the plastic most resistant to impact. Because of its structure, isotactic polypropylene has the highest crystallinity, resulting in good mechanical properties such as stiffness and tensile strength and is regarded as a self-healing plastic due to its ability to reform following impact.

### 3. Breakable components

All other securing devices require a pin, padlock, or ground anchor which can come loose or be damaged upon impact. Items can then become loose, become unstable or worse still- become dangerous projectiles or removed by vandals (more often than not 3 or 4 pins are required to hold an item at a cost of 7-10 dollars each)

**SOLUTION:** Using only friction overcomes the problem of locking mechanisms that often fail creating dangerous litigation risks, unstable items or making it impossible to remove items when required. Smart Sustainable Foundations continue working effectively impact after impact, year after year.

### 4. Dangerous trip factors

Metal devices protrude from the concrete, creating dangerous trip factors and when steel posts shear off, they become extremely dangerous with rough steel edges that create dangerous litigation risks

**SOLUTION:** ZERO Foundations are installed flush with ground level and can be capped off when item is removed. (Tapered cap with no trip factors)

### 5. Rising costs

The cost of metal is soaring and will continue to rise as global shortages worsen

**SOLUTION:** Made from waste product, the cost of ZERO Waste Foundations has not increased on twenty years and with large investment in sustainable manufacturing we hope to be able to continue to deliver our products at low cost for years to come.

### 6. Landfill

Posts installed directly in concrete or metal devices secured in concrete create carbon intensive landfill.

**SOLUTION:** By using ZERO Waste Foundations you ensure concrete is reusable for the next 100 years and steel becomes recyclable.

**If you have any other concerns-  
please let us know- we love to help  
solve your problems**

# Index

You told us your problems, and we listened.....	4
Unit includes.....	6
Advanced engineering.....	7
DOH&S Worksafe Award.....	10
Pack includes.....	11
Safety Procedures.....	17
Reduce cost by 80%.....	18
Approved Nationally.....	19
Main Roads WA.....	19
Roads & Maritime NSW.....	20
Qld Main Roads Dept.....	20
Vic Roads.....	20
Applications.....	21
Impact Resistant.....	22
Impact & Pull Testing Authorities.....	23
Frangibility.....	24
Corrosion resistant.....	25
Responsible Manufacturing.....	26
DRAWINGS.....	27
INSTALLING ZERO WASTE FOUNDATIONS.....	28
INSTALLING BARRIERS AND BIKE RACKS.....	28
REMOVABLE TRAFFIC BOLLARDS.....	28
IMPACT RECOVERY BOLLARDS.....	28

## Unit includes

1. 350 mm Ground Socket
2. 275 mm Self-locking Taper
3. Cap

Self-drilling screws supplied to secure taper to post

Sockets can be reduced to 150 mm. Additional sockets are used to extend depth to 650 mm +, by truncating the base of one socket and inserting into a complete socket. Refer to Directions for use.

Sold in boxes of 25 units- Quantity Discounts provided.

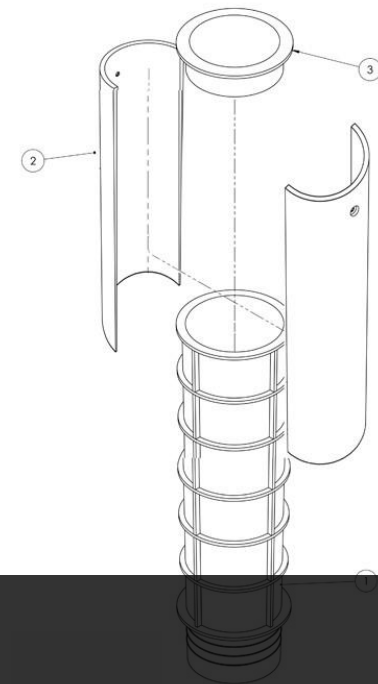

## SELF-LOCKING TAPER

Provided in two halves the self-locking Taper creates an advanced polymer sleeve that fully encircles the post.

The self-locking Taper is attached to the post using self-drilling screws provided and enables items to lock into the ground socket automatically, remaining perfectly aligned safe and secure year after year

Vibrations from wind, traffic or vandals will not loosen the taper, (in fact they will act to increase the locking action) Items cannot become loose or unstable over time and can only be removed using the tools provided.

## GROUND SOCKET

The ground socket is installed in a quality concrete foundation (must be MP3 or greater to be impact resistant) and has a lip that provides a clean black rim that sits flush with ground level.

The socket is tapered internally (dirt, grit and water consequently fall to the bottom of the socket) and do not adversely affect the locking action.

Sockets can be reduced to 150 mm on site or extended by 300 mm increments. No glue required.

Cap prevents access of water and grit. Weak spot provided in base of socket to enable piercing to accept electrical wiring or allow drainage.



## Advanced engineering

Unlike concrete, metal and brittle plastics that are rigid, ZERO Unbreakable Foundations are made using a revolutionary “Smart” polymer (previously only used in the aerospace industry) that is shock absorbing and self-healing, protecting concrete from damage for the entire lifespan of a development



### 1. Advanced polymer

Made using a new age technology previously only used in Aerospace industry, providing unique shock absorbing and self-healing properties, making it highly suitable for this application.

The unique built-in memory allows the material to flex, cushion and reform repeatedly upon impact from vehicles, protecting the surrounding foundations for the entire lifespan of a development

### 2. Unbreakable

This is where it gets really Smart. The locking device uses no mechanical or breakable components, using friction to secure items.

This not only ensures items remain perfectly aligned, safe and secure year after year, it ensures the locking device continues working year after year, and that items are easily removable (using tools provided) no matter how long between removals, overcoming all the problems associated with metal devices

## Self-healing

The built-in memory allows the material to reform repeatedly upon impact from vehicles. When a damaged post is removed, the ground socket returns to its original shape without wear or tear, protecting the surrounding concrete and paving from damage impact after impact.

Both laboratory and in-situ tested from 10 - 110kmph demonstrating no deformation following hundreds of impacts, without any damage to the surrounding foundations.

Over 300kg of upward force is required to remove posts from the ground socket. The locking capacity remains undiminished, and items remain removable using tools provided, following hundreds of impacts.

NB: Where you position the taper on the post determines the locking capacity. Move the taper up the post 20 mm to make items removable by hand (no tools required). It is important users follow the directions to ensure adequate locking capacity for each different application

## 1. Impact Tested

### Tested from 10 – 110 kmph

Awarded Innovator of the Year by Dept of Commerce for developing the world's first truly sustainable solution that continues working for the entire lifespan of a development

## 2. Pull Tested

### Units demonstrated no reduction in holding capacity following multiple impacts

When items are installed with taper flush with ground level units demonstrate no reduction in locking capacity following multiple impacts.

## BOTH LABORATORY AND INSITU IMPACT TESTED AT 10 - 110 KMPH

### ZERO DAMAGE TO FOUNDATIONS

Zero damage to concrete footing or surrounding paving impact after impact for the entire lifespan of a development

### ZERO DAMAGE TO SECURING DEVICE

Only securing device that has no breakable components so continues working for the entire lifespan of a development

### Upon Low Impact

ZERO unbreakable sockets absorb the impact force protecting the surrounding foundations from damage. Combined with ZERO Flexi-posts to make posts also impact absorbing and self-recovering

### Severe Impact

When severely impacted the post bends at ground level (no matter what speed or strength of post) The ZERO unbreakable sockets protect the surrounding concrete and paving from damage for the entire lifespan of a development

### Any strength post

Impact tests were performed on 2.3 / 2.9 / 3.6 / 5mm and solid rod. 2.3- 2.9 bends upon impact from vehicle. 3.6 brings a passenger vehicle travelling >5 kmph to a stop and bends upon impact from heavy vehicle



## 1. Low speed

### Parking signs

When a vehicle impacts a post at relatively low speed (shown right), the post will initially deflect elastically and if there is sufficient momentum and energy in the errant vehicle, the post's bending strength will be exceeded, leading to plastic deformation concentrated near the top of footing as the post bends over.



## 2. Medium speed

### Roads 60 KM Zone

When a vehicle impacts a post at relatively High speed (shown right), the post will initially deflect elastically and if there is sufficient momentum and energy in the errant vehicle, the post's bending strength will be exceeded, leading to plastic deformation concentrated near the top of footing as the post bends over.



## 3. High speed

### Freeways 110 KM Zone

When a vehicle impacts a post at High speed (shown right), the post will initially deflect elastically and if there is sufficient momentum and energy in the errant vehicle, the post's bending strength will be exceeded, leading to plastic deformation concentrated near the top of footing as the post bends over.



# DOH&S Worksafe Award

Dept Occupational Health and Safety Worksafe Award for successfully addressing

1. Digging and heavy labour (body stressing is the No.1 cause of injury)
2. Working in dangerous traffic (No.1 cause of serious injury)
3. Damaging underground services (a growing concern that can be life-threatening)

*"Our selection is not based on price alone; we also took into consideration the safety & saving aspects."*

ZERO Unbreakable Foundations allow quick replacement of items with no further effort required to the base, (providing a significant cost benefit in replacing the damaged item by re-using the existing footing) and reduces risk of injury to employees by reducing time spent on traffic islands exposed to traffic."

**MAIN ROADS WA**



## Items remain safe & secure

Items are simply dropped into position and secured using friction (no pins or metal components that can rust or break). This ensures items are perfectly aligned, remaining safe and secure year after year

## Efficient replacements

Following severe impact items are simply popped out using tools provided. A new item (with taper attached) is simply dropped into position, automatically locking in remaining perfectly aligned safe & secure year after year

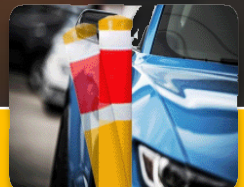
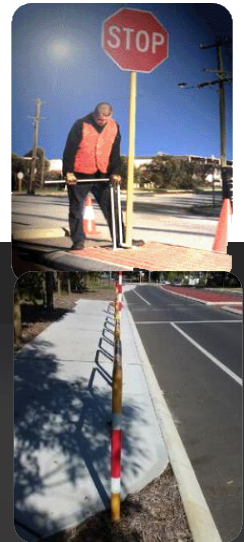

## Pack includes

ZERO UNBREAKABLE FOUNDATIONS  
YOUR BOX CONTAINS

- 25 x Ground Sockets
- 25 x Tapers (supplied in two halves)
- 25 x Re-usable Caps
- 50 x Self-drilling screws
- User Manual



### TOOLS REQUIRED

Tools provided in a pack (or can be purchased individually) See over for details.

### GROUND SOCKETS ONLY

You can buy boxes of ground sockets only - to extend depth of ground socket to 650 mm (or greater). You simply truncate one socket and insert it into a complete socket (no glue required)

Relocating item: You can also use extra sockets to provide additional locations to install the same item/ or for storage when items are not in use.



### TAPER

You can buy boxes of additional self-locking Tapers only - to enable multiple items to be installed in the same location (or to speed up replacements by having spare tapers which will enable items to be prepared in advance- ready to simply drop into position when required)



### IMPACT RECOVERY RINGS

You can buy Impact Recovery Rings to install large diameter bollards (steel/ stainless steel or advanced polymer bollards) on the same 60 mm foundations, making both the bollard and surrounding foundation reusable impact after impact (surface mount option also available).



Description	Depth	Boxed	Dimensions (mm)	Weight
Complete Unit	350 mm	25 units	[400 x 400 x 400]	12 kg
Ground Socket	350 mm	25 units	[400 x 400 x 400]	8 kg
Taper	350 mm	75 units	[400 x 400 x 400]	12 kg
Pack of tools	1m	4 tools	[1200 x 150 x 150]	20kg

# Stop the damage

Unless you incorporate some form of shock absorbing capability, the bollard and footing will need replacing every time it is badly impacted.

**Put an end to costly maintenance for the entire lifespan of a development**



## 60 MM UNITS

Unit includes 350 mm Ground Socket; Self-locking Taper; Cap and screws

PACK OF 25 UNITS

**\$30.00 EA**

## GROUND SOCKET

To extend depth of ground socket to 650mm.

PACK OF 25 UNITS

**\$15.00 EA**

## SELF-LOCKING TAPER

Secure multiple items in same location (remove a bollard, install a table)

SOLD IN PACKS OF 75 UNITS (150 HALF TAPERS)

**\$15.00**

## SET OF TOOLS

Installation tool, Removal Tool (sheared post attachment) and foot removal tool (remove flattened posts)

**\$200.00**

**Buy once- use for a lifetime.  
Go ahead, use me again and again-  
you'll never break me!**

**QUANTITY DISCOUNTS FROM \$25.00 /UNIT**

- Protects surrounding foundations from damage
- Impact resistant (tested 10- 110KM/hr)
- Ergonomic Tools
- Worksafe Award DOH&S
- Approved nationally
- Innovator of the Year

**VIEW BROCHURE** >



# Make Impact resistant

Unless you incorporate some form of shock absorbing capability, the bollard and footing will need replacing every time it is badly impacted.

**Put an end to costly maintenance for the entire lifespan of a development**

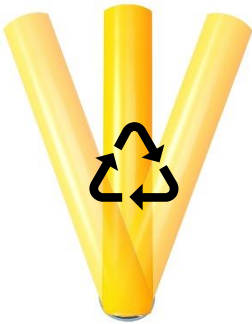

## IMPACT RECOVERY

Bollards can be secured using the ZERO Impact Recovery System making bollards and footings impact resistant & reusable

## S/MOUNT IRS

Suitable for solid concrete footpaths and foundations. Secured using five evenly spaced concrete anchors. Base is reusable

**\$350.00**

## 350/650 DEPTH IRS

We recommend 350 mm Depth footings for most applications. 650 for free standing footings

**\$300.00**

### Upon Low Impact

Bollards remain rigid and appear to be solid inground bollards but when impacted by a vehicle they absorb the impact force deflecting a maximum of 20 degrees and self-recovering, with no diminished capacity following hundreds of impacts

### Severe Impact

When severely impacted instead of the entire footing being dislodged, the inner resistance core bends allowing the bollard to fold but not be dislodged - preventing any further forward movement of the vehicle and enabling fast reinstatement

### Fast efficient replacements

Replacements are simple Following severe impact bollard is easily removed (resistance core replaced) and reinstated in less than 5 mins Bollards and Zero Rings are re-usable impact after impact, year after year

[VIEW BROCHURE](#)

  
**work safe**

# Bollard Design options

ZERO O Rings available to secure steel 150/165 mm (can be powder coated colour of choice), stainless steel 168 mm (Satin finish) or Advanced Polymer bollards 150 mm (available in almost any colour).

**We get knocked down- but we get up again- You're never going to keep us down!**

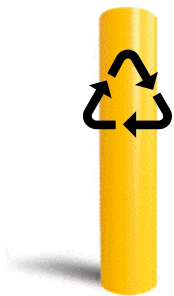

## POLY BOLLARD

Advanced Polymer poly Bollard 150 mm diameter (looks just like steel but far more durable)

**\$150.00**

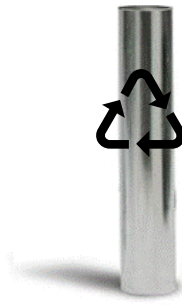

## ST STEEL BOLLARD

Quality stainless steel Pipe bollards -Heavy duty impact resistant and Aussie made to last

**\$400.00**

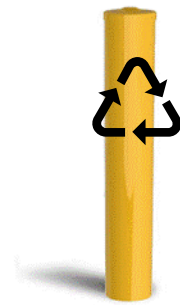

## STEEL BOLLARD

Quality Aussie steel powder coated and striped to MRWA standards. Looks like an inground bollard but far more durable

**\$250.00**

### Safer

Unlike other "Flexible" bollards, ZERO Impact Recovery Bollards have a strong resistance core that provides protection for pedestrians and buildings by preventing deflection beyond 20 degrees.

### More resilient

Bollards become reusable impact after impact. Reduced risk of damage to casing and to vehicles. Foundations also become reusable impact after impact. For the greatest resilience choose advanced polymer bollards.

### Low Cost

Stop paying over and over again to replace the bollard and expensive concrete or paved footings, saving thousands over the life of a development.

[VIEW BROCHURE](#)



**worksafe**



## **Installations are simple**

Instead of taking weeks, you can install the infrastructure for an entire development in a single day without disturbance

Instead of taking weeks to dig up newly laid foundations, (often requiring hours of disturbance and expensive traffic management) sockets are installed by simply positioning upright when pouring concrete (or retrofitted by core drilling or removing pavers).

This creates a perfect finish and items are simply dropped into position, automatically locking in using friction, which ensures all items are perfectly aligned, proving superior safety and aesthetics

## **Replacements simple**

Instead of taking hours, replacements are conducted quickly and efficiently from a standing position, facing traffic. Items are quickly and efficiently removed using an ergonomically designed leverage tool from a standing position. There are even tools for flattened or sheared off posts

## **Substantially reduce risks**

Using traditional methods, it's difficult to budget for roadworks and even more difficult to budget for maintenance.

By using ZERO Unbreakable Foundations you eradicate all risks involved with digging and heavy labour and time spent working in dangerous traffic.

You greatly reduce your risk of time and cost overruns. No risk of back injuries or injury resulting from long hours of digging and heavy labour; Reduced risk of serious injury working in traffic; No risk of damage to underground services; and no risk of time overruns.



Damaged items can now be removed and replaced in less time than it currently takes to erect traffic management. Australian Standards state that if an item can be replaced in less than 5 minutes - No traffic management is required.

**VIEW BROCHURE**





# Safety Procedures

TASK	HAZARDS	WORKING PROCEDURES
<p>Installing Sockets</p> 	<ul style="list-style-type: none"> <li>- Bending of the back</li> <li>- Twisting of the back</li> <li>- Working in traffic</li> </ul>	<ul style="list-style-type: none"> <li>• Dial before you dig</li> <li>• Install appropriate traffic management</li> <li>• Dig hole to insert ground socket</li> <li>• Insert Installation tool inside ground socket</li> <li>• Lower Installation tool &amp; socket into hole and fill with concrete.</li> <li>• Operate installation tool from standing position with straight back</li> </ul>
<p>Installing Items</p> 	<ul style="list-style-type: none"> <li>- Bending of the back</li> <li>- Twisting of the back</li> <li>- Working in traffic</li> <li>- Item not secure</li> </ul>	<ul style="list-style-type: none"> <li>• Install appropriate traffic management/ cones</li> <li>• Attach Taper to item using self-drilling screws provided (This can be done prior to going onsite to reduce time on location)</li> <li>• For 2.9 – 3.6 + wall thickness posts we suggest pre-drilling</li> <li>• Using two hands, drop item firmly into ground socket</li> <li>• Check item is sufficiently installed to protect from unauthorized removal (tap down until no taper protrudes from socket to protect taper from damage when items are impacted)</li> </ul>
<p>Using Removal Tool</p> 	<ul style="list-style-type: none"> <li>- Bending of the back</li> <li>- Twisting of the back</li> <li>- Working in traffic</li> <li>- Trapping of fingers</li> </ul>	<ul style="list-style-type: none"> <li>• Hold both the upright and arm of tool together when carrying tools to avoid trapping fingers</li> <li>• Position a minimum of two safety cones or safety barriers at extremity of working space</li> <li>• Make sure the base of the tool as close as possible to the base of the item before applying jerking action</li> <li>• Apply downward quick jerking action to arm of tool</li> <li>• Lift item from ground socket using two arms (for items over 25 kg, 2 people must lift item from ground socket)</li> <li>• Bend knees to insert cap in ground socket/ or insert new item</li> </ul>

## Reduce cost by 80%

If you've been in the industry for a while, you will know that around 80% of your work results from the most vulnerable items in city centres or carparks (approximately 20% of all items)

Once these locations are made sustainable the only cost is around 20 seconds labour for all future replacements. (80% which will be repeats)

- No dial before you dig
- No major traffic management
- No ongoing concrete supplies
- No paving supplies
- No digging or heavy labour
- No risk of body stressing
- No risk of damage to underground services
- Reduced time working in dangerous traffic
- No disturbance to traffic

**With rapid urbanisation and depleting resources, those that do not act now will pay dearly as the damage, workload, risks and costs are about to increase dramatically.**

The longer we delay in making our cities sustainable, the greater the cost (environmentally, socially and financially) and each year the difficulty performing this work continues to grow.

Instead of remaining in a constant state of decline, (growing increasingly costly and difficult to maintain) we can now begin to heal our cities, one foundation at a time.

These sustainable cities don't only look great- the more foundations made sustainable- the safer. More dynamic and efficient a city becomes.

### 80/20 RULE

**80% of your workload comes from 20% of locations**

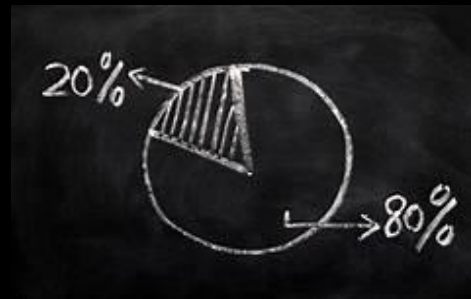

Instead of paying \$300- 1000+ for every future replacement, the only cost is a few seconds' labour. and the best part is that you continue saving year after year for the next 100 years.

# Approved Nationally

## MAIN ROADS APPROVED

For securing posts (no limitations on size or weight of sign) grabrails and traffic bollards.

Circular Hollow Section (CHS) signposts must be secured using an approved fixing device as specified in Annexure 601G (Smart Taper – now called ZERO Unbreakable Foundations)

## MAIN ROADS APPROVED USE OF CHS POSTS AND FRP POSTS

MRWA 60 mm diameter removable bollards (as per MRWA standard drawing [200831-0014](#)) are for use adjacent to high speed roads where access is required for emergency vehicles or over-sized vehicles but you want to prevent access to the general public.

An example of this is the oversize vehicle turnaround bay on Roe Hwy just north of Great Eastern Hwy, the bollards prevent members of the general public from performing an illegal U-turn but allow oversized vehicles to travel from Roe Hwy northbound to Great Eastern Hwy eastbound without going under the bridge.

AREA	SIGN SIZE	
	A & B	C & D
METROPOLITAN PERTH AND BUILT-UP AREAS	76x38x2.0 RHS or 60.3 CHS 2.3	75x50x2.5 RHS 60.3 CHS 2.9
RURAL AREAS SUBJECT TO TROPICAL CYCLONES (REGIONS C&D - DWG. 9430-506)	75x50x2.5 RHS 60.3 CHS 2.9	75x50x2.5 RHS 60.3 CHS 2.9
RURAL AREAS NOT SUBJECT TO TROPICAL CYCLONES (REGIONS A&B - DWG. 9430-506)	76x38x2.0 RHS or 60.3 CHS 2.3	75x50x2.5 RHS 60.3 CHS 2.9

will remove they must be 60 mm diameter with a 2.9 mm wall thickness (as per the standard drawing) considered frangible for speeds of 80 km/h and greater.

## MRWA SIGNAGE

### [ANNEXURE 601](#)

Removable Signposts are defined as signposts which enables the posts to be removed and reinstated from their base with specially designed tools without damaging either the base or post, Removable signposts shall be used, where specified, for all removable signs on High-Wide Load corridor routes.

Removable signposts may also be used in locations where signs are frequently hit, and the removable post design enables the post to be replaced using the existing footing. Alternative types of removable signposts used shall be as specified in Annexure 601G (Smart Taper – ZERO Unbreakable Foundations)

## MRWA GRAB-RAILS

MRWA grabrails can be installed using ZERO Unbreakable Foundations. MRWA is updating the specifications – refer to Cale Mariano MRWA

## MRWA TRAFFIC BOLLARDS

### [VIEW SPECIFICATIONS](#)

## Main Roads WA

*"ZERO Unbreakable Foundations (previously Smart Taper-lock) provide a significant cost benefit in replacing the damaged signpost by re-using the existing footing.*

*Our selection is not based on price alone, also the safety & saving aspects. The Smart Taper-lock allows the quick replacement of posts, with no further effort required to the base and reduces risk to employees by reducing time spent exposed to traffic!" MRWA*

Approved for securing posts, grabrails and MRWA Traffic bollards.

### [MRWA Specs 601 Signs](#)

## Roads & Maritime NSW

---

Functional requirements include:

- The use of this device is permitted, subject to:
- The device supporting a post in a stable vertical position under service conditions,
- Presenting no additional hazard beyond that inherent with the use of 50 Nominal Bore (60.O.D.) steel posts,
- Preventing the unauthorized removal of posts,
- Facilitating the removal and replacement of posts following damage or when otherwise required.
- The device requiring specialized tools for signpost removal, and
- The device being used strictly in accordance with the manufacturer's instructions.

Chris Ford [Bob O'Keefe/ Ross Walsh] RTA 1/3/2000.

## Qld Main Roads Dept

---

### 8.2.2 Signposts

For signs less than 1m<sup>2</sup> in area, the post size is generally 50NB x 3.2mm CHS. Refer to Appendix. B for determination of post sizes suitable for larger signs or heights.

### 8.2.5 Posts in sleeves

There are certain situations where it is advisable to install the post into a sleeve inserted into the footing, such as:

1. Where a sign is located on an urban median strip where it may be struck frequently.
2. Where it may need to be removed occasionally, to accommodate the swept path of over-dimensional vehicles when turning.

This arrangement is only appropriate for small posts up to 50mm nominal bore (60 O.D. CHS Posts). Details of a typical sleeve assembly are presented in Drawing No. 1368 (Appendix D). Variations on the basic theme are just as effective.

*"ZERO Unbreakable Foundations have an 'as-of-right' approval on this basis"* John. C. Douglas Qld MR

## Vic Roads

---

*"We have no objection to the use of the Smart Sustainable Foundations on roadworks provided the system is used consistently with Vic Roads specifications".* John Eldridge

Relevant Vic Roads specifications include Standard Specification Section 714.

# Applications

The wider the application

- the better use of space
- the better use of infrastructure
- the safer the infrastructure
- the more dynamic a development becomes
- the more efficient a development becomes
- the greater the savings
- the less waste

ZERO Unbreakable Foundations are used to secure

- Traffic and parking signposts (any size or weight)
- Grabrails
- U-bars
- Barriers
- Bollards (60- 168 mm diameter)
- Seating
- Fencing
- Tables
- Street furniture
- Statues
- Bins

Items become interchangeable, making developments dynamic.

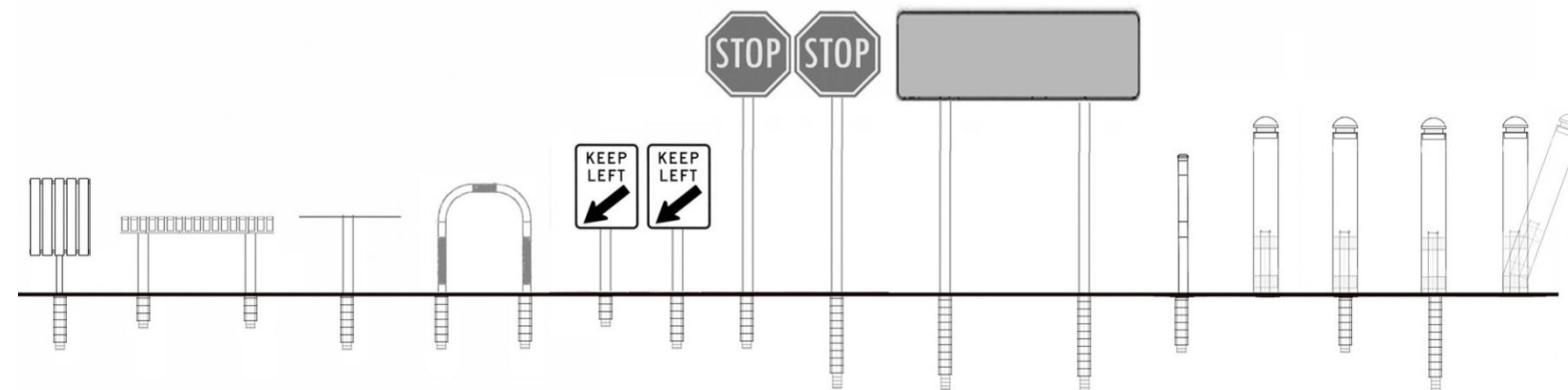

## Impact Resistant

Good quality concrete can last 100 years, but as no road-side item or steel securing device will last this long, by securing items using metal devices or embedding items of infrastructure in concrete creates a never-ending cycle of carbon waste and consumption of vital resources that we can no longer afford.

The ZERO Unbreakable Foundations create a protective impact absorbing and self-healing shield between the item and the valuable concrete foundations, protecting the foundations from damage and putting an end to the on-going consumption of valuable carbon supplies for concrete and paving repairs.

## Frangibility

To minimise risks associated with errant vehicles, for a shock absorbing mechanism is employed to limit impact force and the consequent impact force acting on the surrounding concrete footings

For parking and traffic signposts, it is vital for the safety of drivers that the posts are frangible.

> The measure of post frangibility is based the post's bending strength.

> 60 OD Grade 350 CHS Steel post with a wall thickness of 3.2 or less, having a bending strength below 3.34 kN.m are considered frangible, for all speeds. Any higher strength will provide resistance against bending when impacted by a passenger vehicle

> ZERO Traffic Bollards made using 60 OD Grade 350 CHS with a wall thickness of 2.9 are recommended for use on highways with a speed of 100km+

> To minimise risks associated with errant vehicles, for heavier or larger posts (such as traffic light columns and bollards), a second shock absorbing mechanism is employed to limit impact force and the consequent vehicle deceleration.

### LOW SPEED IMPACT

When a vehicle impacts a post at relatively low speed (shown right), the post will initially deflect elastically and if there is sufficient momentum and energy in the errant vehicle, the post's bending strength will be exceeded, leading to plastic deformation concentrated near the top of footing as the post bends over.

The maximum impact force can be estimated from the following:  $F1 \times \text{Height of Impact} = Ms$ . Note the 'design strength' has been divided by the capacity reduction factor 0.9 to obtain the 'nominal strength'). Assume Height of Impact = 0.5m.  $F1 = 3.34/0.9/0.5 = 7.42 \text{ kN}$ , approx. = 750kg force.

### HIGH SPEED IMPACT

When a vehicle impacts a post at a high speed (Diag.2), the response of the post is somewhat different to the low-speed impact.

For example, the inertia of the post above the point of impact is likely to cause an extra zone of plastic bending (or hinge) to form close to the point of impact, as show on the right.

> The corresponding force to cause this bending will be  $F2 = 2 F1 = 1,500\text{kg}$  force (as an inflection point will be at a height of 0.25m).

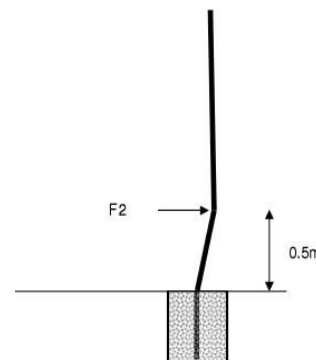
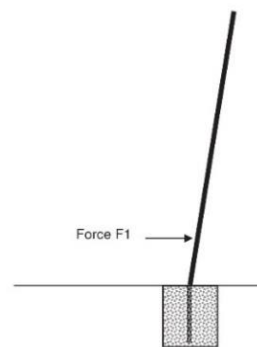

# Impact & Pull Testing Authorities

## TEST 1: Locking Capacity Tests: Conducted by Unirig Pty Ltd.

If secured with less than 5 mm of Taper protruding (we recommend taper is installed flush), over 250 kg of upward force is required to remove items secured using the Smart Self-locking Taper.

## TEST 2: Durability Tests: Conducted by Unirig Pty Ltd.

The Smart Self-locking Taper is highly resistant to damage. Even if the top half of the socket was sheared away the taper would continue to hold effectively.

## TEST 3: Impact Tests: Automotive Safety Engineering Pty Ltd.

Impact from a vehicle will not adversely affect the Smart Self-locking Taper. The post will bend at the surface of the concrete footing (or paving) and the foundations will remain undisturbed.



*“Demonstrated no diminished holding capacity following successive extractions”*

**“From the tests I would recommend the Tapers are adequately effective with 5 mm or less protruding above the top of the ground tube. Successive extractions do not materially change the effectiveness of the Smart Taper System. “**

H.J.Perkins B.Sc Eng (Hons.) FIE (Aust). CP (Eng)

### PERKINS WORKINGS

Test Certificate No UTS 14562

### AAKER UNIRIG PTY LTD

Certificate No UTS 14747-1

### Automotive Safety Engineering Laboratories Pty Ltd

Impact Tests

# Frangibility

To minimise risks associated with errant vehicles, for heavier or larger posts (such as traffic light columns and bollards), a special shock absorbing mechanism is employed to limit impact force and the consequent vehicle deceleration.

However, for the smaller posts, the practical approach used is to ensure the posts are frangible.

> The measure of post frangibility is based the post's bending strength.

> 60 OD Grade 350 CHS Steel post with a wall thickness of 3.2 or less, having a bending strength below 3.34 kN.m are considered frangible, for all speeds. Any higher strength will provide resistance against bending when impacted by a passenger vehicle

> Smart Urban Traffic Bollards made using 60 OD Grade 350 CHS with a wall thickness of 2.9 are recommended for use on highways with a speed of 100km or greater

## 110kmph Speed zone



## 60kmph Speed zone



## LOW SPEED IMPACT

When a vehicle impacts a post at relatively low speed (shown right), the post will initially deflect elastically and if there is sufficient momentum and energy in the errant vehicle, the post's bending strength will be exceeded, leading to plastic deformation concentrated near the top of footing as the post bends over.

The maximum impact force can be estimated from the following:  $F1 \times \text{Height of Impact} = Ms$ . Note the 'design strength' has been divided by the capacity reduction factor 0.9 to obtain the 'nominal strength'). Assume Height of Impact = 0.5m.  $F1 = 3.34/0.9/0.5 = 7.42 \text{ kN}$ , approx. = 750kg force.

## HIGH SPEED IMPACT

When a vehicle impacts a post at a high speed (Diag.2), the response of the post is somewhat different to the low-speed impact.

For example, the inertia of the post above the point of impact is likely to cause an extra zone of plastic bending (or hinge) to form close to the point of impact, as show on the right.

> The corresponding force to cause this bending will be  $F2 = 2 F1 = 1,500\text{kg}$  force (as an inflection point will be at a height of 0.25m).

## Parking

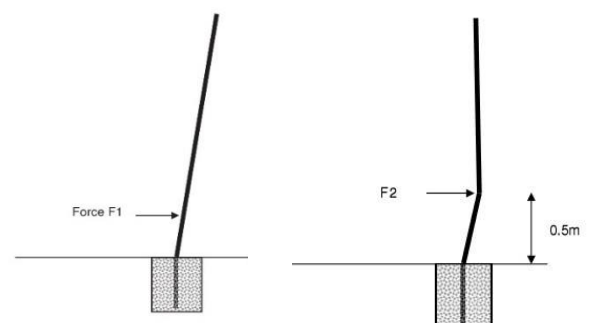



## Corrosion resistant

The expected lifespan of a steel post, or fixing device is around 10 years, but poor-quality steel can rust out in less than 3 months.

In the past five or so years we have seen massive influx of cheap Asian posts (with the majority of suppliers now supplying Asian imported steel, posts can last than 3 months before rusting out at the base)

If corrosion effects are considered in the design phase and the right decisions made prior to construction, structures can be built to last and protected for far longer. An asset can be optimised or extended, and maintenance time and costs can be reduced.

- **Problem 1:** Metal is prone to rust and corrosion even if galvanised.
- **Problem 2:** Concrete creates a corrosive force reducing the lifespan of metal installed directly in concrete.
- **Problem 3:** Metal imported from China is often low quality and quickly rusts out creating dangerous litigation risks
- **Problem 4:** Metal post-securing devices require a pin or padlock which can rust and corrode creating dangerous litigation risks and reducing the lifespan of road-side infrastructure
- **Problem 5:** Metal on metal can scratch the surface removing the galvanising

**Solution:** The ZERO Unbreakable ground socket forms a protective shield between the metal post or item of infrastructure and the concrete, reducing the risk of rust and corrosion.

The self-locking taper (secured to the item using galvanised screws) encircles the post protecting the post from the corrosive nature of concrete

### Drainage

A hole can be pierced in the bottom of the socket (and rubble placed beneath the socket) to enable drainage

### No rusting pins or padlocks

Using only friction to secure items overcomes the problem of metal pins or padlocks that can rust and corrode creating dangerous litigation risks, unstable items or making it impossible to remove items

### Infrastructure becomes corrosion resistant

Items of infrastructure secured on ZERO Unbreakable Foundations are protected from corrosion and are removable from the concrete foundation, making them re-usable and 100% recyclable



## **Responsible Manufacturing**

Steel is NOT a renewable resource. It is a non-renewable resource cannot be naturally replaced. Typically, non-renewable resources are found in the ground, such as rocks, fossil fuels and minerals. Once they are depleted, they are gone forever. Steel is made from these fossil fuels and minerals.

### **ENVIRONMENTALLY FRIENDLY MATERIALS**

ZERO Unbreakable Foundations are made using the world's most environmentally friendly plastic made from the waste produced when refining petroleum and unlike steel and concrete, the more we use the greater the environmental impact

Polypropylene is 100% recyclable.

### **ENVIRONMENTALLY FRIENDLY MANUFACTURING PROCESSES**

We have invested a great deal of money to ensure we can manufacture units using the most energy efficient and environmentally friendly methods and maintain our low prices

### **LOCALLY MADE**

Despite the majority of manufacturers going offshore to take advantage of substantially lower manufacturing costs, we continue to manufacture locally, supporting our local economy, .

### **WE MAINTAIN OUR LOW PRICES**

We have priced our products below metal devices (and with fast depleting resources metal devices will continue to increase their prices). Despite major cost increases we have managed to maintain our low prices for more than two decades. In Europe these products are now retailing for almost ten times the price we charge- this is evidence of our commitment to helping you build a better future.

## Drawings unit

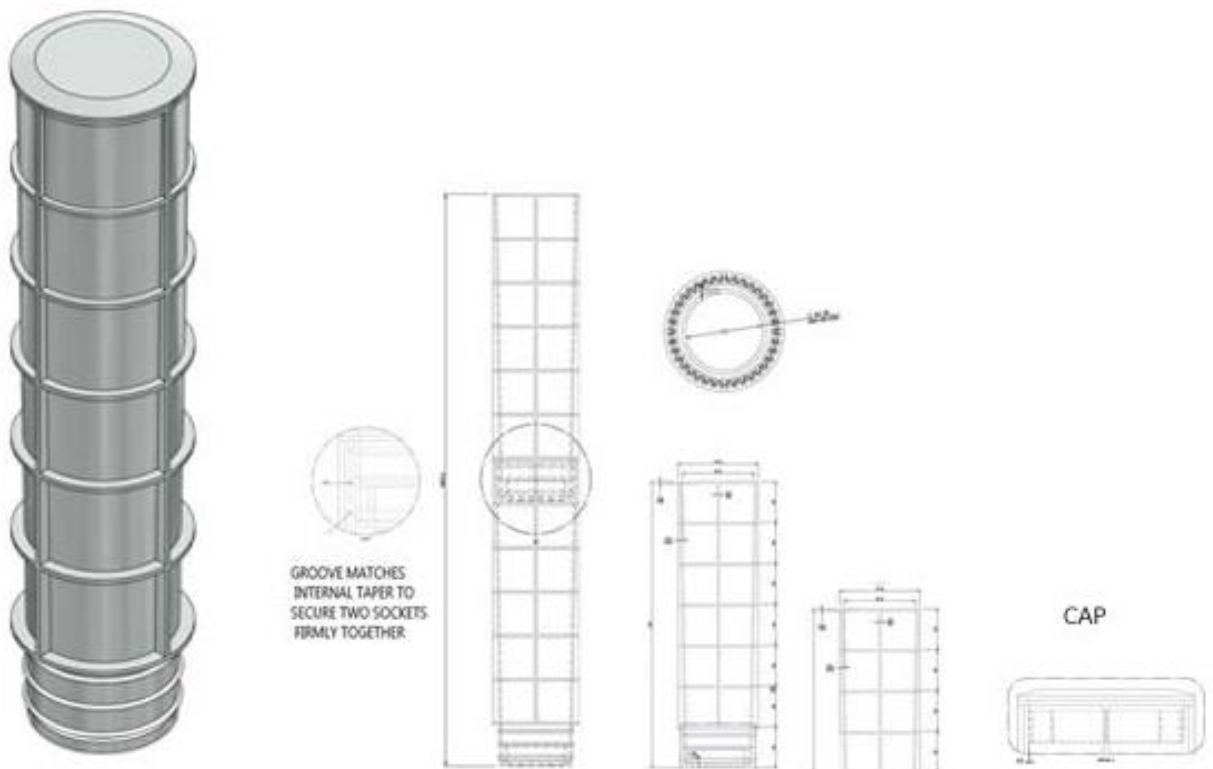
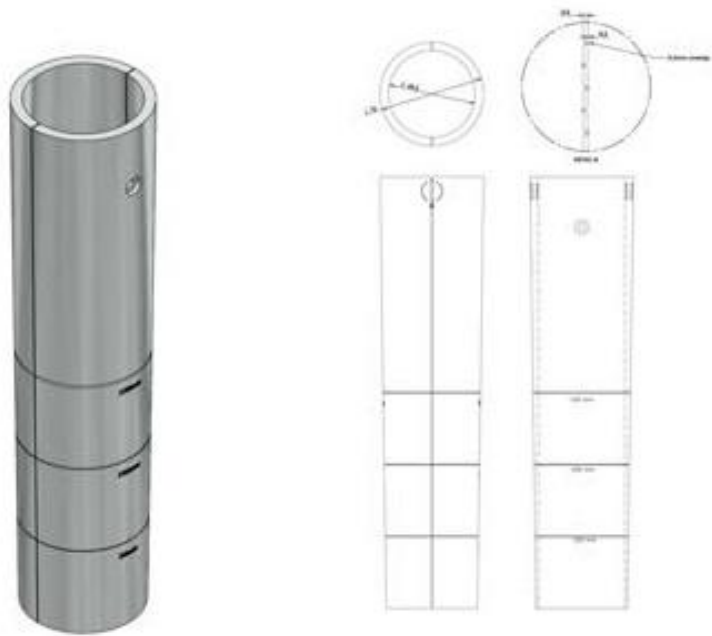

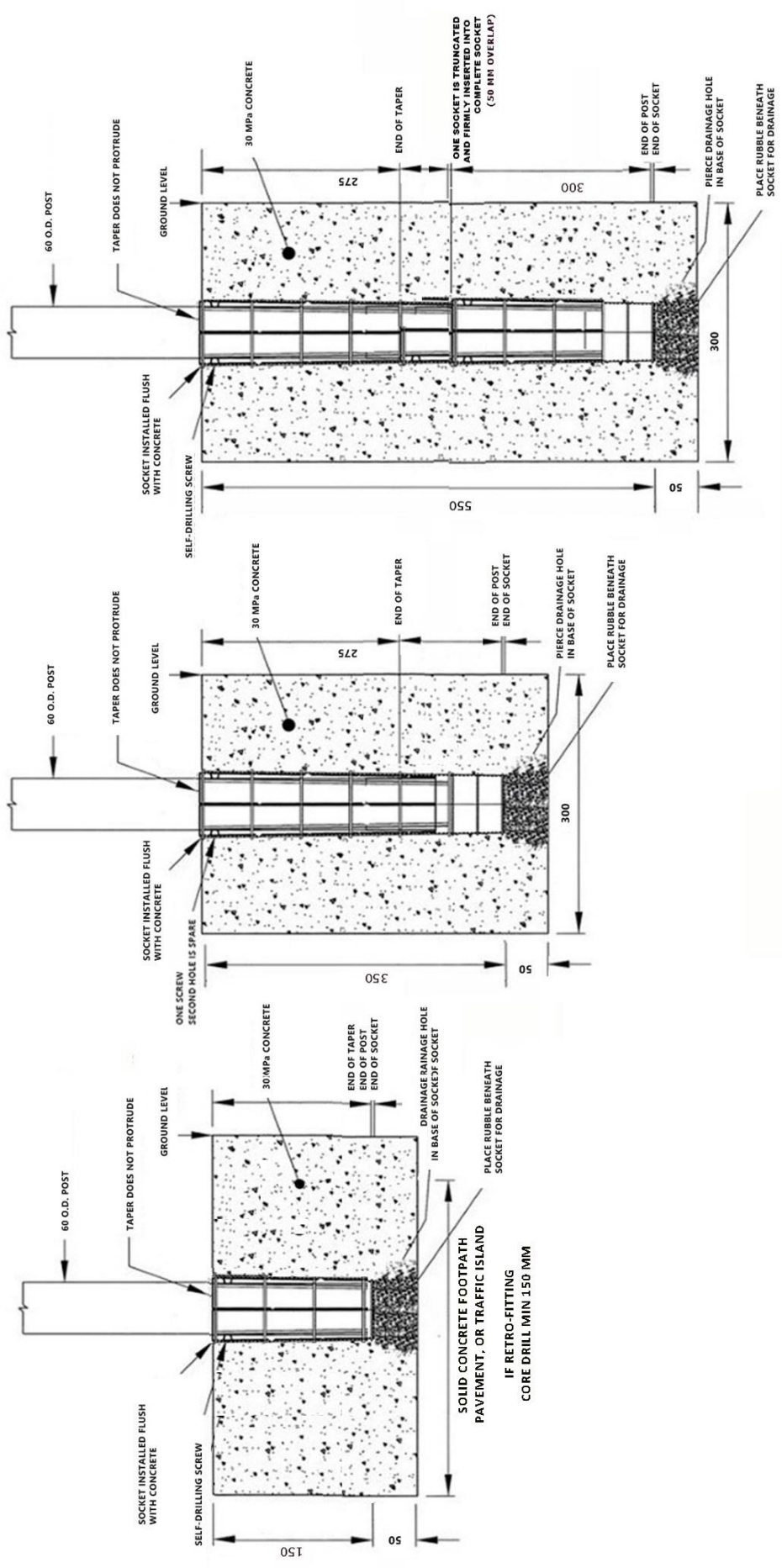

**ZERO WASTE**

**INSTALLING ZERO WASTE FOUNDATIONS**

**BIKE RAIL**  
 50MM DIA, GRADE 316,  
 1.6MM WALL THICKNESS, SATIN  
 FINISH STAINLESS STEEL PIPE.  
 20MM SQUARE X 1500MM LONG MS  
 GALV HOLLOW TUBE CENTRALLY  
 WELDED TO BASE OF EACH LEG.

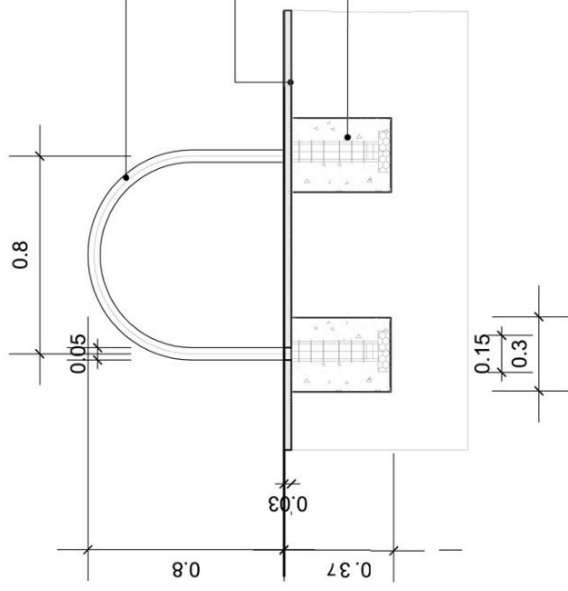

**ASPHALT PAVING**  
 ASPHALT PAVING TO MATCH EXISTING  
 LAID OVER CONCRETE FOOTING.

**FOOTING**  
 370MM DEEP X 300MM SQUARE 32 MPA  
 CONCRETE FOOTING SET 30MM BELOW  
 TOP OF SURROUNDING ASPHALT PAVING.  
 FOOTING LAID ON LAID ON COMPACTED  
 ROADBASE.

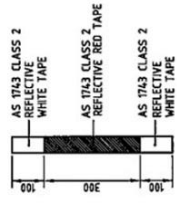

**ASPHALT PAVING**  
 ASPHALT PAVING TO MATCH EXISTING  
 LAID OVER CONCRETE FOOTING.

**SMART FOOTING**  
 400MM DEEP X 300MM SQUARE  
 CONCRETE FOOTING SET FLUSH  
 TOP OF SURROUNDING ASPHALT

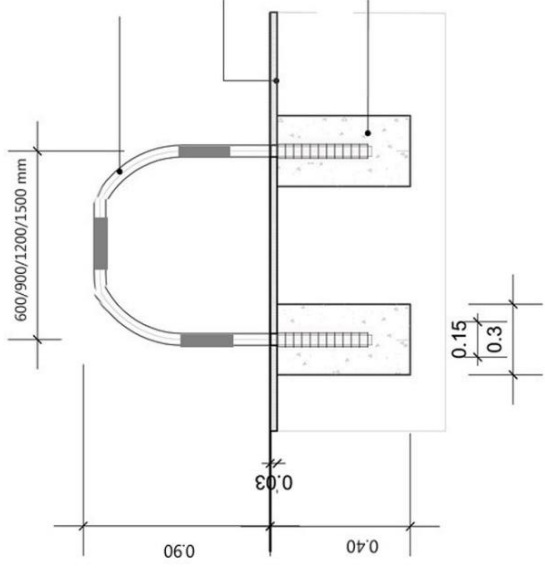

**SECTION THROUGH GRABRAIL**

**SCALE: 1 TO 20**

**SECTION THROUGH BIKE RAIL**

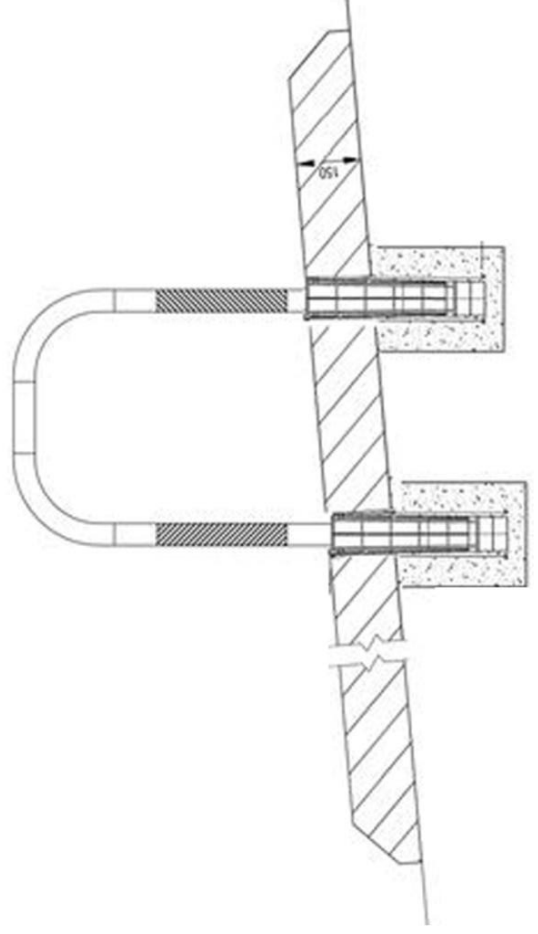

**ZERO WASTE**

**INSTALLING BARRIERS AND BIKE RACKS**

WARRINGTON AND BIRNIE WARRINGTON

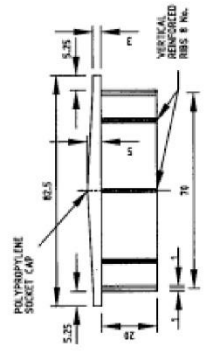
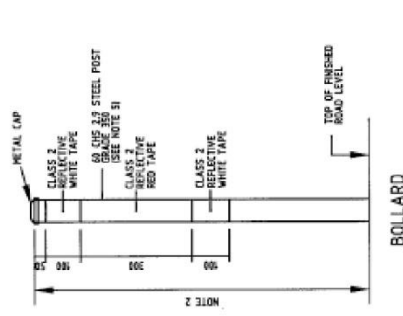

ELEVATION SOCKET CAP

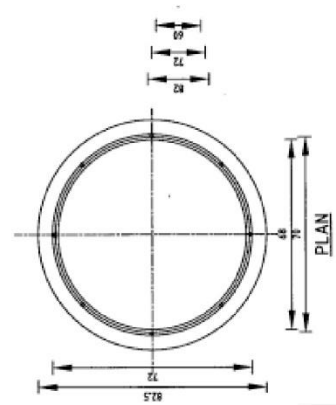

PLAN

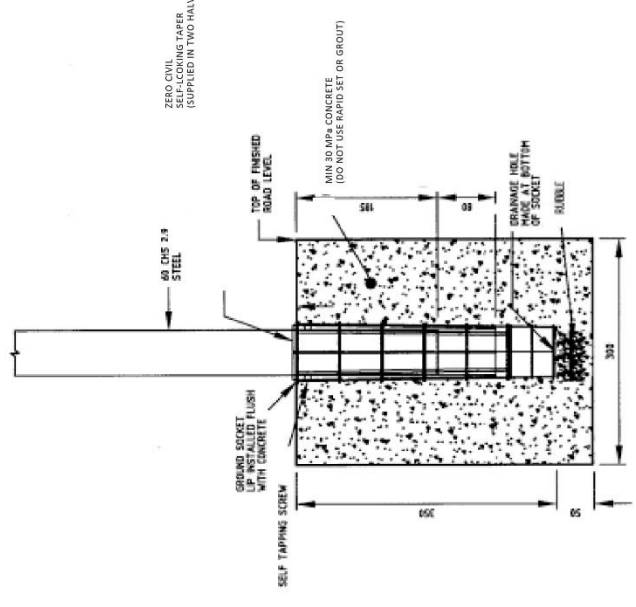

SECTIONAL ELEVATION FOOTING

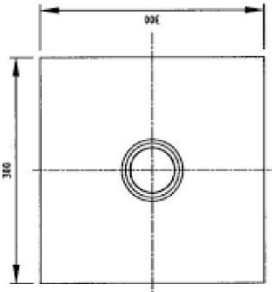

PLAN

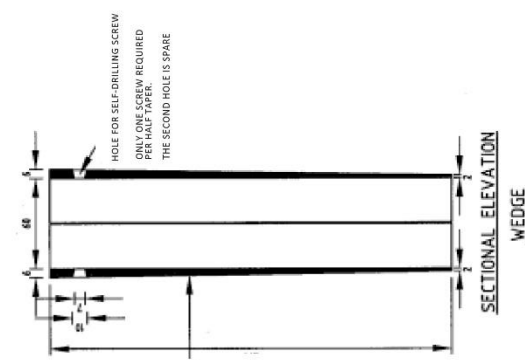

SECTIONAL ELEVATION WEDGE

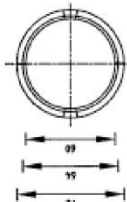

PLAN

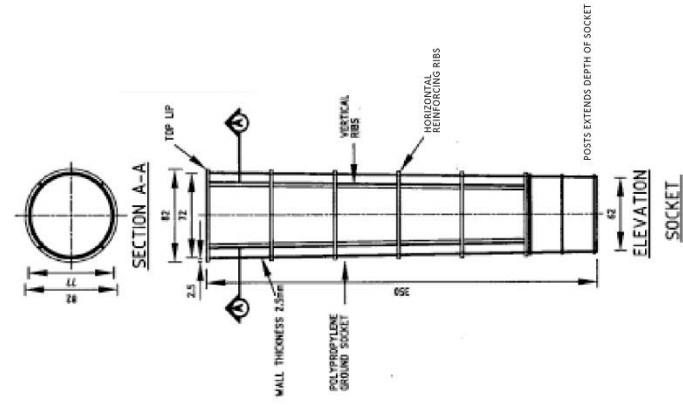

ELEVATION SOCKET

SECTION A-A

**NOTES**

THESE FOOTINGS ARE PERMANENT SO PLEASE TAKE CARE

1. INSTALLATION TOOL AVAILABLE
2. SPACING OF BOLLARDS SHOULD BE IN ACCORDANCE WITH DRAWINGS
3. SOCKET SHOULD BE CAPPED WHEN POURING CONCRETE OR ASPHALT AND WHEN BOLLARD IS REMOVED
4. MUST USE A MIN OF 30 MPa CONCRETE TO ENSURE IT IS IMPACT RESISTANT  
DO NOT SUBSTITUTE FOR FLEXIBLE GROUT OR RAPID SET CONCRETE
5. BOLLARD SHOULD FINISH 900 MM ABOVE GROUND LEVEL
6. DO NOT SUBSTITUTE GROUND SOCKET FOR METAL SOCKET
7. FOR FURTHER INFORMATION CALL ZERO CIVIL +618 924 5545
8. REFER MRWA SPECIFICATION DRAWING 200831-0014
9. TAKE CARE TO COLOUR MATCH SURROUNDING FOOTINGS
10. TOOL REQUIRED TO REMOVE BOLLARDS- MRWA MAINTENANCE TEAMS HAVE TOOLS

For use adjacent to high speed roads where access is required for emergency vehicles or oversized vehicles but you want to prevent access to the general public. The bollards prevent members of the general public from performing an illegal U-turns but allow oversized vehicles access to avoid low bridges and the like. The support vehicles for the oversized load will remove and replace the bollards when necessary. Only Zero Civil 60mm diameter with a 2.9mm wall thickness bollards can be used as they are considered frangible for speeds of 80km/h and greater.



**REMOVABLE TRAFFIC BOLLARDS**

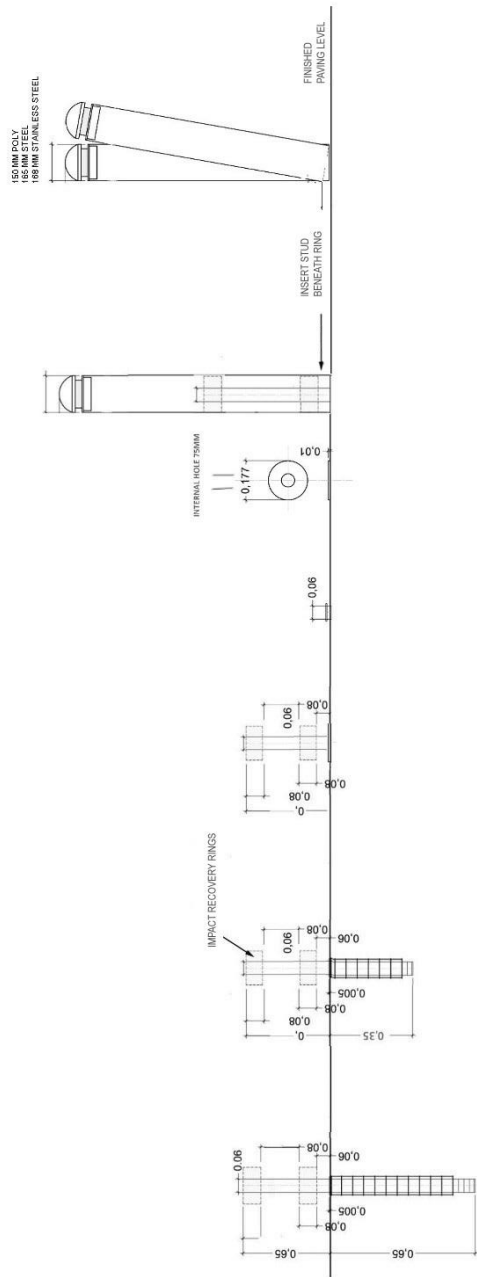
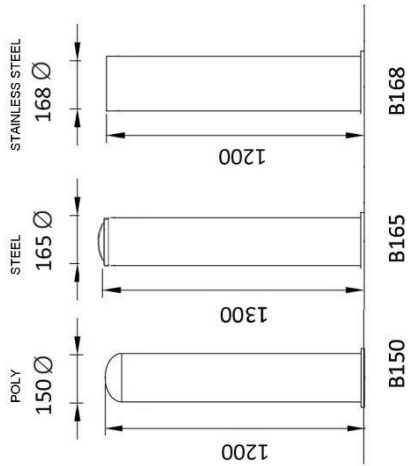

**650 MM DEPTH    350 MM DEPTH    SURFACE MOUNT CAP    PROTECTIVE BASE PLATE    BOLLARD**

**COMPONENTS**

- 1. IMPACT RECOVERY RINGS
- 2. INTERNAL CORE 300 MM HIGH 3.6 WALL THICKNESS
- 3. BOLLARD CASING - POLY/ STEEL OR STAINLESS
- 4. SECURING STUD (SECURITY STUD AVAILABLE)

Stud is inserted in hole at base of bollard and sits below the bottom Impact Recovery Ring

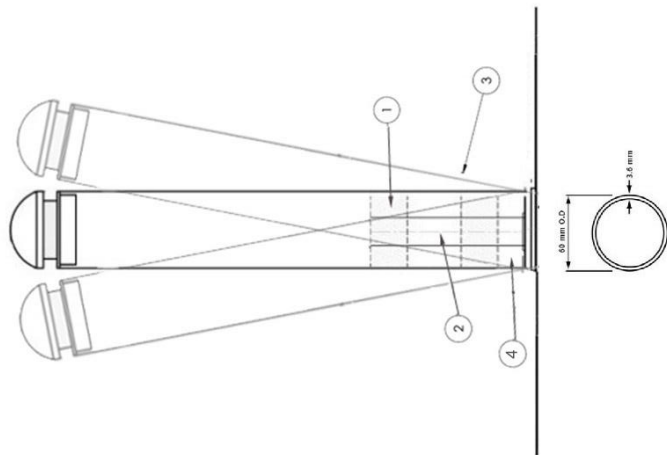

**IMPACT RECOVERY BOLLARDS**

## UNIT INCLUDES

1. Ground Socket
2. Self-locking Taper
3. Cap
4. Self-drilling Screws

Approved Nationally.  
Sold in Packs of 25 Units.  
Tools Required.

Sockets are 350 mm depth and can be altered from 150-650 mm+ Install any size or weight item - simply increase size footing accordingly

## There's no need to get down and dirty

A self-locking taper is attached to the item and the item is simply dropped into the ground socket automatically locking in using friction, which ensures items remain safe and secure, perfectly aligned impact after impact, year after year

Items are simply popped out using ergonomic tools from a standing position. Instead of taking hours- all replacements take literally seconds.



**Go ahead, use me  
again and again -you  
won't break me!**

**08 92485545**  
**hello@zerocivil.com**  
**zerocivil.com**